

**Delta Load Pod**

**Product Data Sheet 19/10**

**Product Description**

Enerco loading pods are formed by creating a bolt on, easy to assemble structure in front of the existing building. Wherever there is a space issue, or the existing building does not allow internal ramps, or tail board access is not available, the Enerco loading pod provides the ideal solution.

Each pod is tailored to suit your operational requirements but typically includes the hinged or telescopic dock leveller, the dock seal, loading bay door and accessories i.e. wheel guides, traffic light, dock lights etc.

Pods can be mounted at 90 degrees or at an angle to the building if space and turning areas are an issue



**Platform**

Each pod is designed specifically for your requirements. The design depends on the surrounding structure, the loading likely to be exerted on the front, the load required to be taken by the platform, the type of vehicles, etc. Incorporated in to the platform will be the dock leveller whether hinged or telescopic lip. The size of the loading pod will depend if any storage is required or whether the goods are going to be taken away immediately.

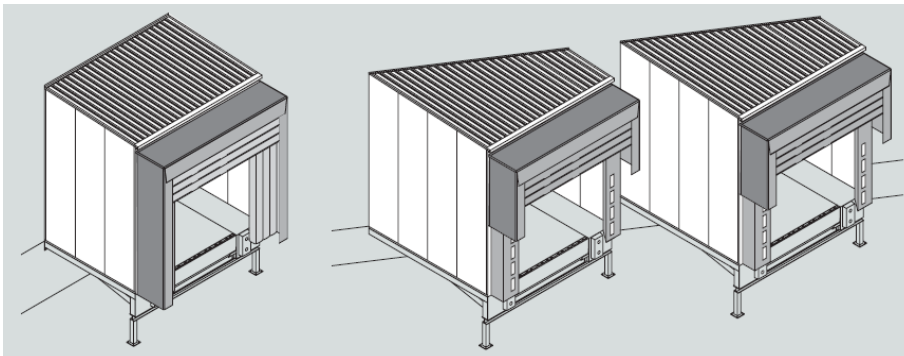

The under sides of the pods can be left open for easy cleaning and storage for the tail lift of vehicles or it can be completely closed.

Above the pod the walls and roof can be manufactured for un-insulated profiled cladding sheets or 40mm thick insulated panels. The roof drainage is either allowed to fall to one side or be collected in a gutter and drained to corner.

The pod will require a solid base on which to be sited however the structure is adjustable in height to allow for any level differences. These are temporary structures and therefore can easily be disassembled and re-erected in a different location or premises.

The loading pod fully protects your goods and using dock shelters or seals as part of the installation maintains security, protection and often temperature control.

Loading can be done at right angles to the building or at an angle, the pods can be supplied individually or as a several unit arranged in a row. These unit can be fitted at angles to the building to assist with turning areas and manoeuvring.



The above installation shows the dramatic effect. Prior to the installation of this loading pod, the goods are left standing outside, unprotected and the warehouse / loading bay staff are exposed to the elements. Following the installation the goods are protected and staff far more efficient.

### Warranty

The Delta Load Pods are supplied with a 24 month parts and labour warranty as standard providing the equipment is maintained in accordance with the manufacturer's instruction and not modified in any way whatsoever. Full details of the servicing requirements are available.

### Servicing

To help protect your investment and extend the effective working life of the equipment, full maintenance packages are available and, in most cases, we can maintain all of your existing doors and loading bay equipment. The door must be serviced at least once per annum.

Full details of our preventative maintenance packages are available on request. Enerco recommend the first service is carried out 6 months after installation.

We have Worksafe Contractor, CHAS and Construction Line accreditation as well as being active members of the Doors and Hardware Federation (DHF) where we have their seal of approval for the service and maintenance of doors. We ensure that our staff are trained to the highest standard and all have an NVQ qualification in line with current industry guidelines This NVQ is in addition to the CSCS Health and Safety, First Aid, Asbestos Awareness and other training including product training applicable to our industry and is continually being updated.



Other products in the Delta range from Enerco include: -

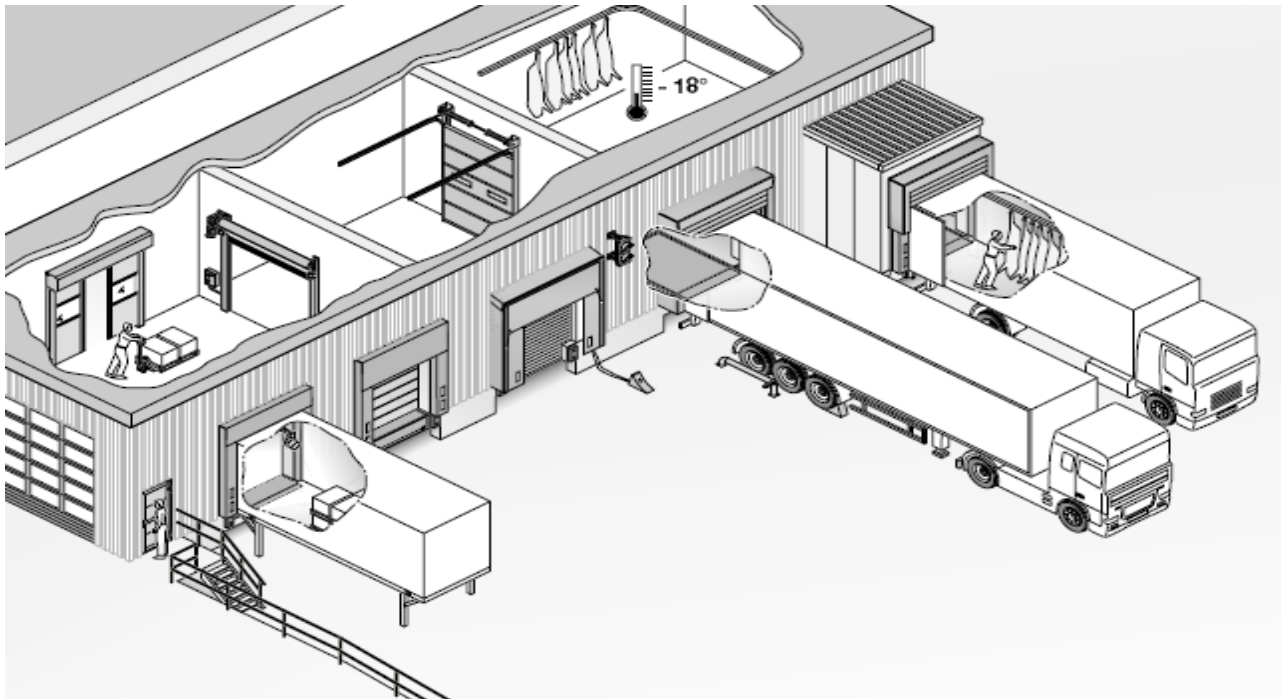

Delta Guard – Commercial Shutters  
Delta Check – Fire Roller Shutter  
Delta Slide – Insulated Overhead Doors  
Delta Part – Bi – Parting & Sliding Doors  
Delta Steel – Steel Security Door Sets  
Delta Bar – Fixed & Removable Window Bars  
Delta Seal – Dock Sealing Systems  
Delta Speed – High Speed Doors  
Delta Service – Service and Repairs  
Delta Glide – Garage Doors  
Delta Glaze – Aluminium Glazed Door Systems

Delta Roll – Steel Roller Shutter Doors  
Delta Secure – High Speed Security Doors  
Delta Insudoor – Insulated Roller Shutters  
Delta Strip – Strip Curtains  
Delta Fold – Steel Sliding Folding Shutters  
Delta Lift – Scissor Lifts  
Delta Shield – Perimeter Security  
Delta Grille – Retractable Window Grilles  
Delta Load – Loading Bay Accessories  
Delta Crash – Rubber, Polyurethane & PVC Swing Doors

Please contact our sales team for more information on 01525 289322 or a brochure. Alternatively visit our web site [www.enerco.co.uk](http://www.enerco.co.uk) or [www.enercohighspeeddoors.co.uk](http://www.enercohighspeeddoors.co.uk)

We reserve the right to change the specification or alter the product data sheet without prior notification.