

## Delta Level 2000 Telescopic Lip Pit Mounted & Suspended Frame Dock Leveller

Product Data Sheet  
9 / 2

### Product Description

The Delta Level 2000 is one of our ranges of telescopic lip dock levellers. Dock levellers are indispensable for fast loading and unloading. They are specifically designed to bridge the gap between the vehicle deck and the loading equipment and at the same time level the difference in height between the ramp and the loading platform. Telescopic lip levellers are ideally suited for the unloading of tightly packed trailers where precise location of the lip is of paramount importance. The platform and telescopic lip can be moved precisely by operation of the up, down, extend and retract buttons



Mounted on a concrete or steel pit base the Delta Level 2000 telescopic lip dock leveller incorporates its own heavy-duty sub-frame. The platform plus lip (500mm or 1000mm long) operates hydraulically via an integral power pack fixed on the leveller sub frame.

Designed, tested and manufactured in UK to meet European Standard EN1398 with full operational load capacity ranging from 6000 - 10000kg per single axle (9000 - 15000 kg rated load).



### Platform Deck

To be of (6mm thick over the flat of the steel, 8mm thick over the Durbar finish) non-skid plate supported by purpose made longitudinal hinging at rear on pivot shafts manufactured from grade F111, F112 & F114 steel. Hot rolled steel channel (100mm x 50mm on platforms up to 3500mm long or 120mm x 60mm above 3500mm) is used to provide maximum strength and flexibility to the platform deck.

### Telescopic Lip

Heavy-duty lip is manufactured from 12/14mm thick Durbar plate steel. This enables easy smooth transfer on to the vehicle deck. The width of lip at the front is either 1800 / 2000 or 2200mm subject to model and application.

### Sub Frame

The dock leveller incorporates a unitary construction that incorporates a reinforced rear member for attachment to the rear pit edge angle. The transfers of imposed loads from the platform (whether parked or elevated) are transmitted in a controlled manner to the pit base.

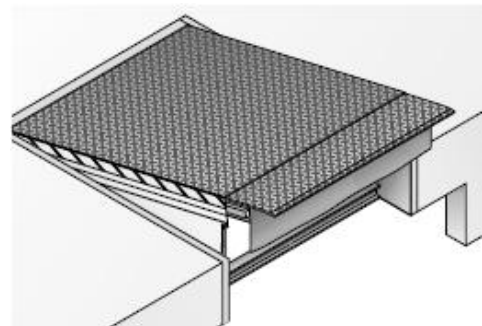

### Platform/Deck Tilt Facility

To facilitate side inclinations, the platform is manufactured from high tensile steel allowing the structure to twist up to 100mm of transversal inclination enabling loading/unloading of uneven vehicle floors. The special rear hinge design maintains a level plane at the rear of the dock whilst tilt is in operation.

### **Finish**

All steel components are treated with an industrially proven paint system incorporating rust inhibitors and finished with Enerco standard colour Blue RAL 5010. Other colours are available as an extra.

### **Electrical**

Motor is 380-420V 3 phase 1.1 kW protected to IP54. The supply voltage required is 3 phase, neutral and earth. At 20°C the nominal starting current is 7.4 amps, with full load current 2.65 amps. Client's isolator requirement is 20 amp 415v plus earth fused at 16 amps.

### **Control Voltage**

Is 24v dc via a transformer housed within the wall mounted control box and has protection to IP55. Two push button operation controls the up and down movement, and a larger highly visible RED emergency stop push button is also incorporated.

### **Wiring**

The cable is of sufficient length to permit the control box to be wall / pier mounted up to a height of 1.6m above internal floor level. Standard length of cable is 7m. The cable is extremely flexible and oil resistant. Standard wiring covers for fitting of control box within 1 m of leveller pit side.

### **Hydraulics / Pump**

This is directly coupled to the motor with integral factory set control valves.

### **Cylinders**

One double acting, 60mm outer diameter, 30mm piston diameter cylinder is employed for the control of the hinged lip. One single acting displacement cylinder for units up to 3500mm long and two cylinders above 3500mm long are used for above and below dock control. These cylinders are 80mm outer diameter, 50mm piston diameter. All cylinders have double hard chrome shafts for improved durability.

### **Side Toe Guards**

Are to be solid steel sheet, two-piece, to provide maximum safety through the full operating range of the dock leveller. Yellow and black hazard stripes are to be provided to the visible edges of both the platform toe guards and the sub-frame.

### **Hose Failure**

The lift cylinder is fitted with a hose failure valve to arrest and control platform descent in the unlikely event of hose failure.

### **Emergency Stop**

The emergency stop button can be brought into effect at any time during the operating cycle by pushing the auto-locking (stay put) RED button on the control box. Normal operating status can be resumed by releasing the RED button, and operating the "UP" button. The emergency stop button must not be depressed during loading as the dock leveller will not remain in float mode.

### **Auto Reset Button (Controlled)**

This is an extra option if required. This is an additional BLUE button mounted on the control cabinet which when pressed will automatically activate the parking procedure. One press of the BLUE button will automatically park the dock leveller by raising the platform, lowering the lip and finally returning the platform to the cross traffic position.

### **Operation**

The "RAISE" push button is depressed to lift the platform to the required height, the RAISE button is released and the "EXTEND" button depressed. When the lip has been extended sufficient to reach the rear of the trailer the "EXTEND" button is released and the "DOWN" button depressed. The lip will lower slowly and rest on the rear of the trailer. The hydraulic system will now allow the platform to float in unison with the rear of the trailer as it rises and lowers whilst loading and unloading.

**In the unlikely event that a vehicle unexpectedly departs from the loading bay, the valve arrangement ensures automatic arrest of the platform movement thereby improving safety of both forklift trucks and personnel.**

To park the dock leveller the "RAISE" button is held depressed. The platform will rise to its full height and the lip will automatically retract to its fully retracted position. Once retracted the RAISE button is released and after a slight delay the platform will lower slowly until the platform reaches the parked position.

The controls of the telescopic dock leveller are all dead man operation allowing the platform and the lip to be infinitely positioned to suit the trailer position and height.

### Installation

The pit must be constructed with absolute accuracy and provided with edge angles. Depending on the style of pit, the pit edge angles are fitted differently. In essence three designs are available

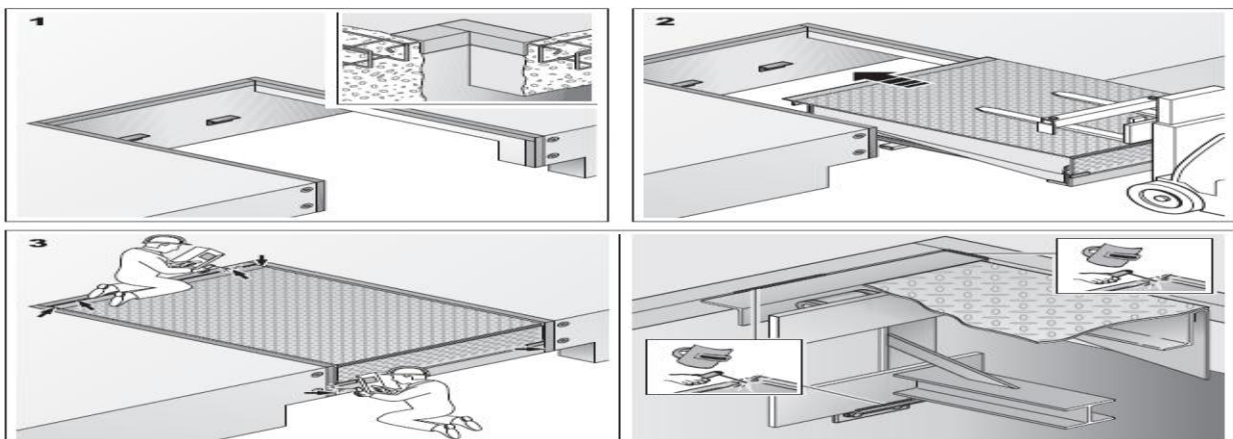

If pit mounted, angles cap off the concrete to form the edge of the pit on all 6 sides (5 sides if suspended frame as shown above). With this design, the dock leveller is simply lifted into the pit, shimmed and levelled to suit the surrounding floor level, bolted to the concrete base or welded if steel and welded across the full width of the rear hinge angle.

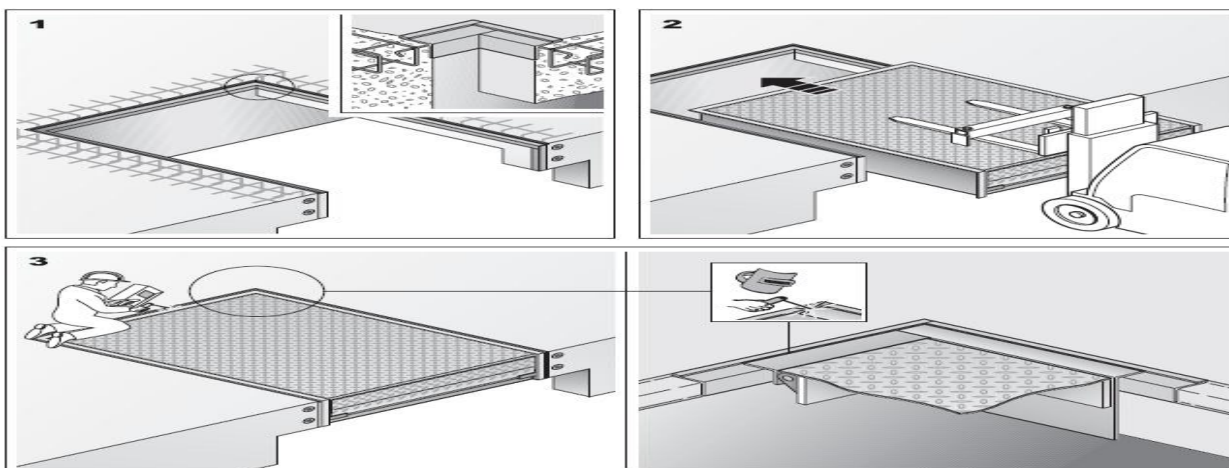

If suspended frame (generally used when tail lift vehicles are used), the top three sides of the pit edge angles are equipped with a 10mm square bar. The top of the 10mm bar is set to the top of the finished floor level. When the suspended frame dock leveller is lifted into the pit, the outward facing dock leveller frame angles sit on top of the pit edge angle so that the top of the dock leveller is flush with the finished floor level. This system can be used for both tail lift and non tail lift pits.

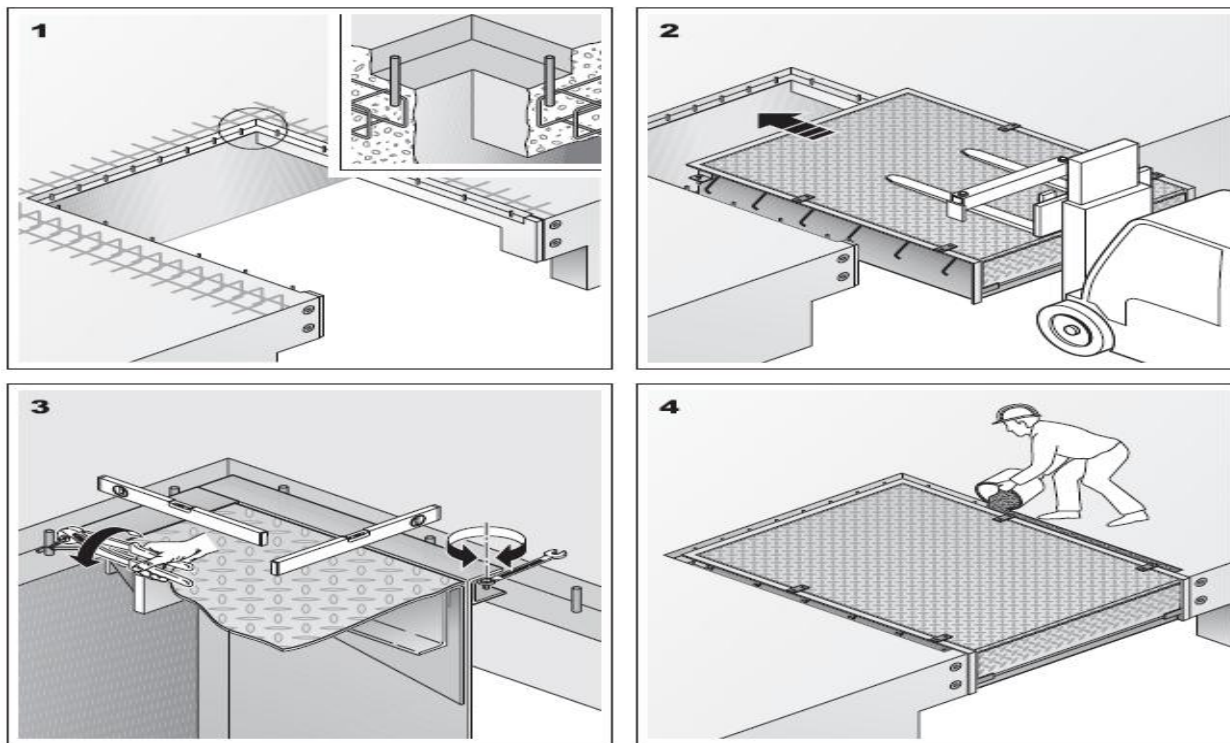

The second suspended frame design does not require a pit edge angle set. The pit is cast leaving a 100mm deep x 150mm rebate around the edge of the pit. The pit will have a series of reinforcement pins placed around it. The dock leveller is lifted into place, shimmed and levelled to the finished floor level. The dock leveller frame tangs are then welded to the pins. The customer then infill's the rebate to finish the mechanical installation.

### Warranty

The Delta Level 2000 is supplied with a 24 month parts and labour warranty as standard providing the equipment is maintained in accordance with the manufacturer's instruction and not modified in any way whatsoever. Full details of the servicing requirements are available.

### Servicing

To help protect your investment and extend the effective working life of the equipment, full maintenance packages are available and, in most cases, we can maintain all of your existing doors and loading bay equipment. The door must be serviced at least once per annum.

Full details of our preventative maintenance packages are available on request. Enerco recommend the first service is carried out 6 months after installation.

We have Worksafe Contractor, CHAS and Construction Line accreditation as well as being active members of the Doors and Hardware Federation (DHF) where we have their seal of approval for the service and maintenance of doors. We ensure that our staff are trained to the highest standard and all have an NVQ qualification in line with current industry guidelines. This NVQ is in addition to the CSCS Health and Safety, First Aid, Asbestos Awareness and other training including product training applicable to our industry and is continually being updated.



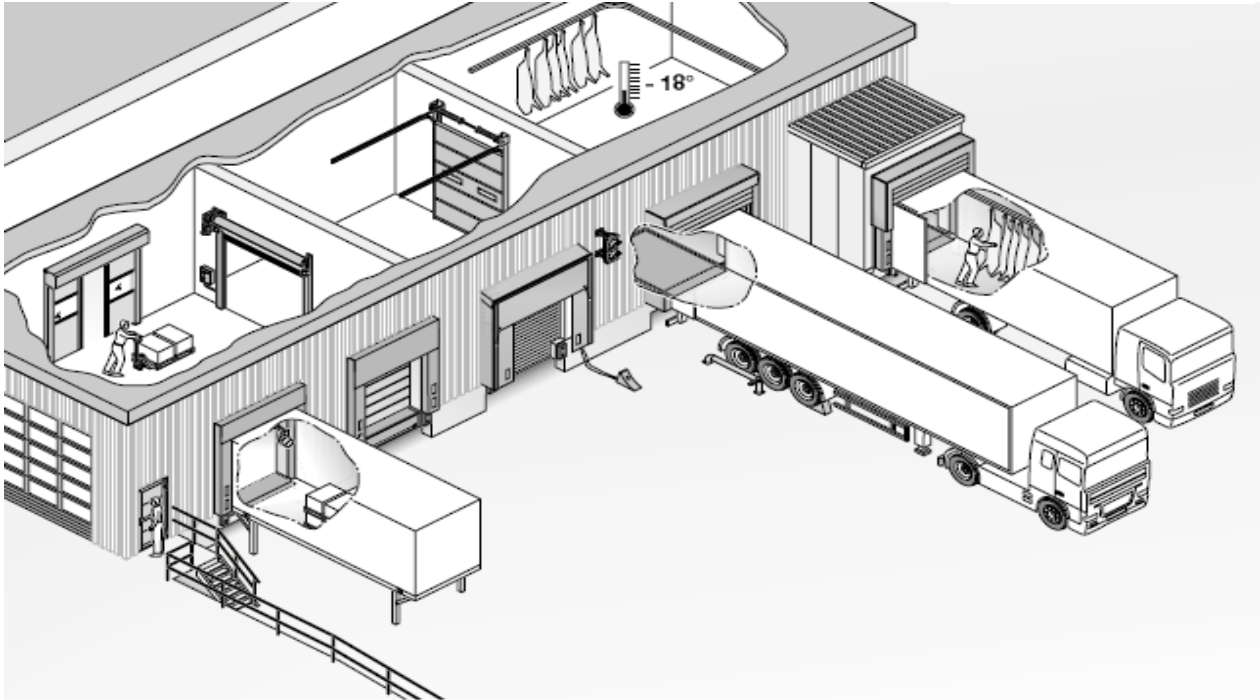

Other products in the Delta range from Enerco include: -

- |   |  |
|---|--|
| Delta Guard – Commercial Shutters           | Delta Roll – Steel Roller Shutter Doors              |
| Delta Check – Fire Roller Shutter           | Delta Secure – High Speed Security Doors             |
| Delta Slide – Insulated Overhead Doors      | Delta Insudoor – Insulated Roller Shutters           |
| Delta Part – High Speed Bi – Parting Doors  | Delta Strip – Strip Curtains                         |
| Delta Steel – Steel Security Door Sets      | Delta Fold – Steel Sliding Folding Shutters          |
| Delta Bar – Fixed & Removable Window Bars   | Delta Lift – Scissor Lifts                           |
| Delta Seal – Dock Sealing Systems           | Delta Shield – Perimeter Security                    |
| Delta Speed – High Speed Doors              | Delta Grille – Retractable Window Grilles            |
| Delta Service – Service and Repairs         | Delta Load – Loading Bay Accessories                 |
| Delta Glide – Garage Doors                  | Delta Crash – Rubber, Polyurethane & PVC Swing Doors |
| Delta Glaze – Aluminium Glazed Door Systems |  |

Please contact our sales team for more information on 01525 289322 or a brochure. Alternatively visit our web site [www.enerco.co.uk](http://www.enerco.co.uk) or [www.enercohighspeeddoors.co.uk](http://www.enercohighspeeddoors.co.uk)

We reserve the right to change the specification or alter the product data sheet without prior notification.