

Delta Speed 5030SE Internal High Speed Door

Product Data Sheet
3 / 5

Product Description

The Delta Speed 5030SE high-speed door is one of our range of fast action doors, offering proven individual system solutions for almost any technical requirements up to 5.0m wide x 5.0m high. All Enerco high-speed doors are manufactured in modular design and are almost maintenance free. This results in outstanding operational reliability, fast and inexpensive repairs when damage occurs, as well as low operating costs. This is especially true of this door with its patented rubber bottom edge virtually eliminating bottom rail repairs. High-speed doors protect from drafts, keep temperature zones at a constant temperature and insulate against noise. In addition to this, they help to improve the working atmosphere.

The door can be fitted with complete all round safety controls i.e. photocells at low level housed on the door columns and fail safe opto-electric safety edge.



Product Advantages

1. Emergency opening using the emergency lever and counterbalance weight.
2. Fast opening (0.8m/s standard, 3.0m/s optional) and closing (0.8m/s) with safety.
3. Will operate normally in wind pressures of over 40km/h.
4. Fabric curtains are colour impregnated PVC with optional window sections.
5. Anti-crash system with automatic restart.



In a crash situation the flexible vertical profile is pressed undamaged out of the guides. The door stops instantly.



If necessary, bring the Soft Edge profile onto the feed in side of the door. Operate the door to travel up.



In the top section, the curtain, assisted by the brushes, automatically feeds itself back into the guides again. The repair is complete.

Applications

- To minimise energy losses by automatically opening and closing, quickly and safely.
- Minimise draughts and maintain constant temperatures
- As a partition between factory areas.
- In busy traffic doorways.
- Improves the working environment.
- Enhances aesthetic appearance.

Door Design

The curtain is made from a Polyester fabric that is coated with colour impregnated PVC. On the Model 5030SE, the stability of the curtain is achieved via the proven aluminium profiles and at the bottom by the sturdy horizontal Soft Edge bottom profile.

The side columns, manufactured from galvanised steel, are opened easily for maintenance.

The standard version does not include a motor cover.



Spring wind protectors with track guided rollers ensure curtain stability

Door Drive Mechanism and Control Panel

The door is powered both up and down by a 415v 3PH/N/E geared brake motor.

Controls consist of an integrated control panel that controls all of the door functions including the failsafe diagnostics required for the photocell and safety edge. Further benefits include as standard interlock capability, induction loop cross traffic detection and many others. The control panel is equipped with up and stop push buttons.

Safety Features

- Photocell protection (standard)
- Electric safety edge (optional).
- Emergency opening lever

All safety features are self-diagnostic and fail-safe.



Remote Controls

The door can be supplied with additional remote controls. These fall into two categories, activation and safety. When wired to activate, they will open the door from its closed position, stop the door from closing when open and stop / reverse the door when closing.

When wired to safety the features are the same as to activate however the door will not open when closed.

Remote controls include induction loops, photocells, radar, push buttons / pull switch operation or radio / infrared controls.

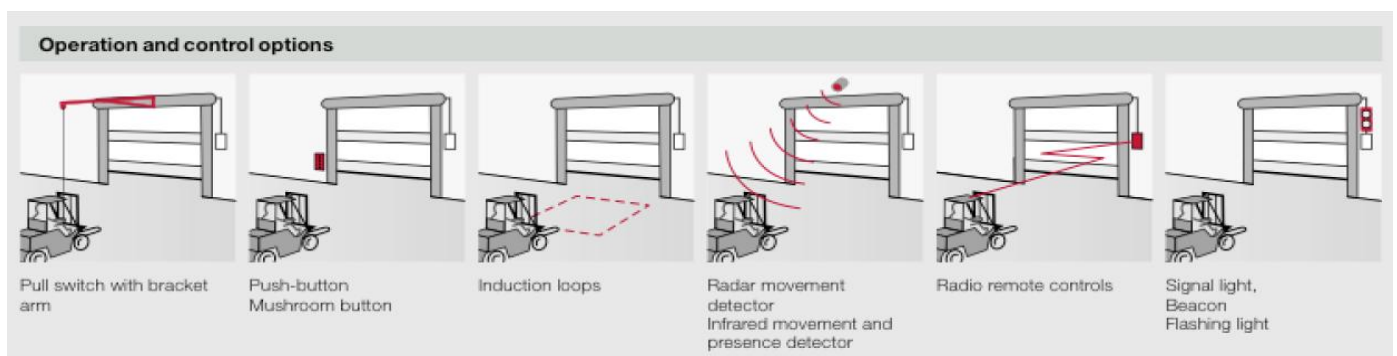

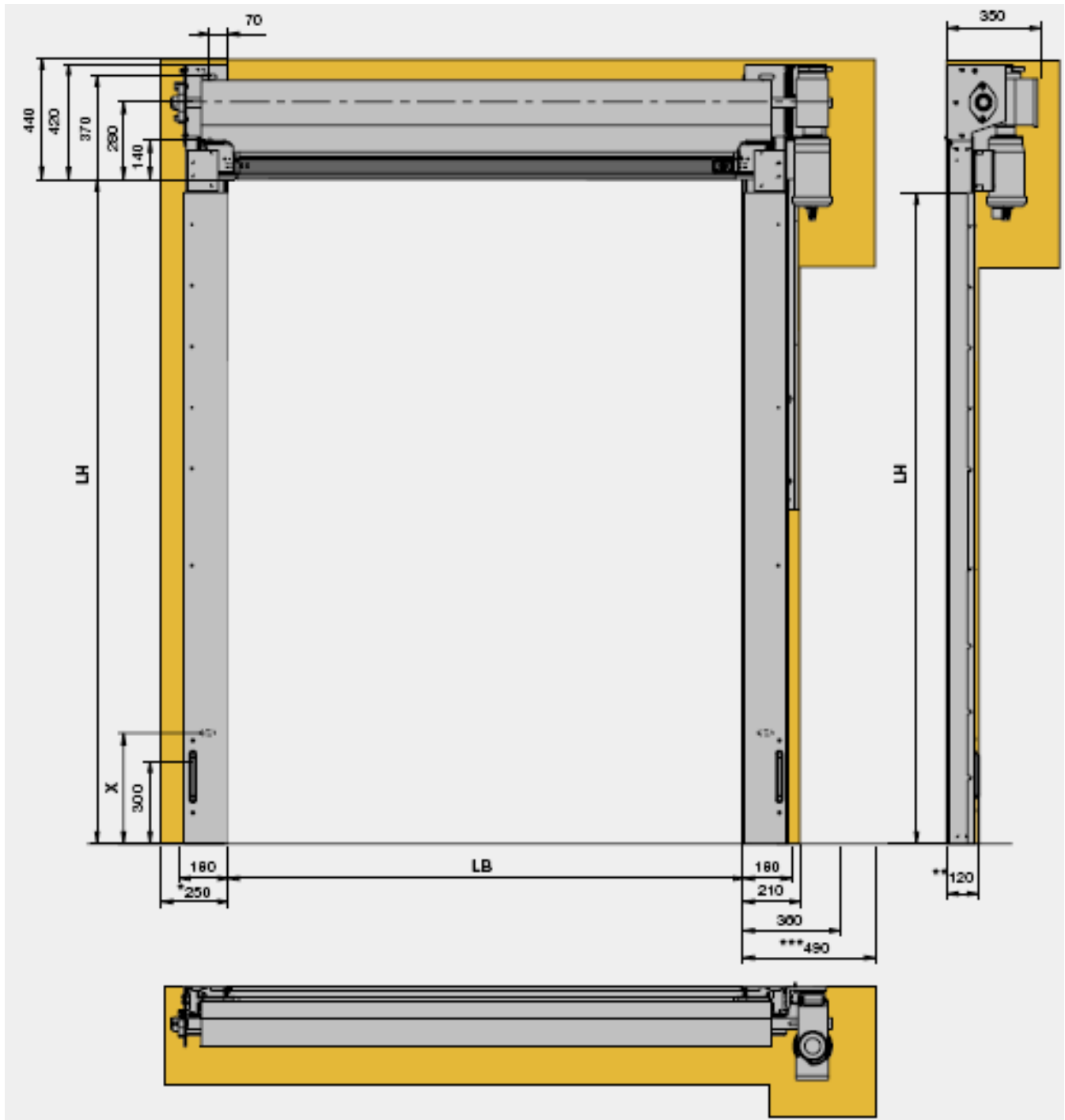

- * For version with emergency opening 320mm
- ** For version with emergency opening 180mm
- *** Space required for dismantling operator
- X is job specific

General Arrangement of Delta Speed 5030SE with no cladding

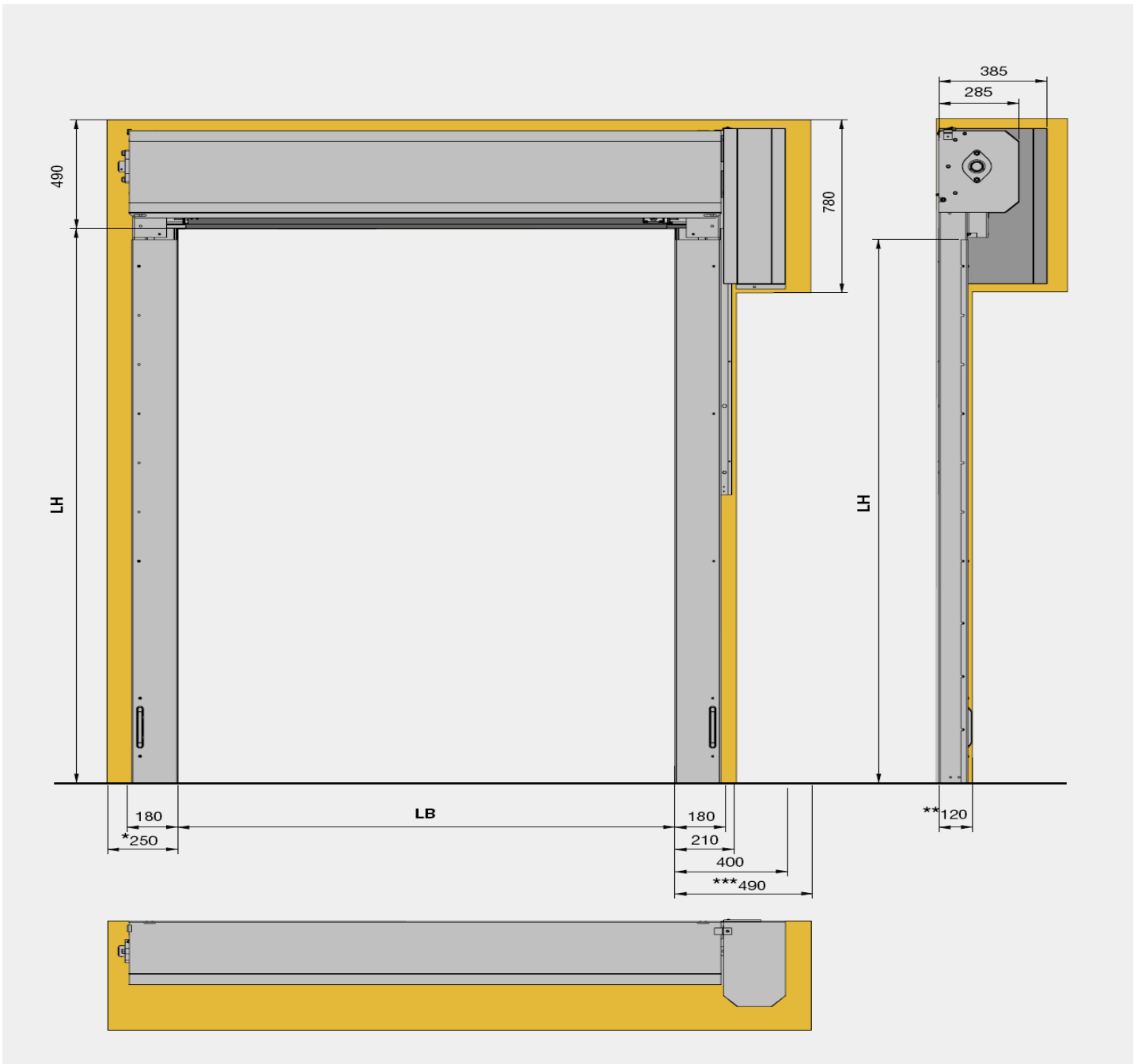

- * For version with emergency opening: 320mm
- ** For version with emergency opening: 180mm
- *** Space required for dismantling the operator
- X is job specific

**General Arrangement of Delta Speed 5030SE
With Full Cladding Straight**

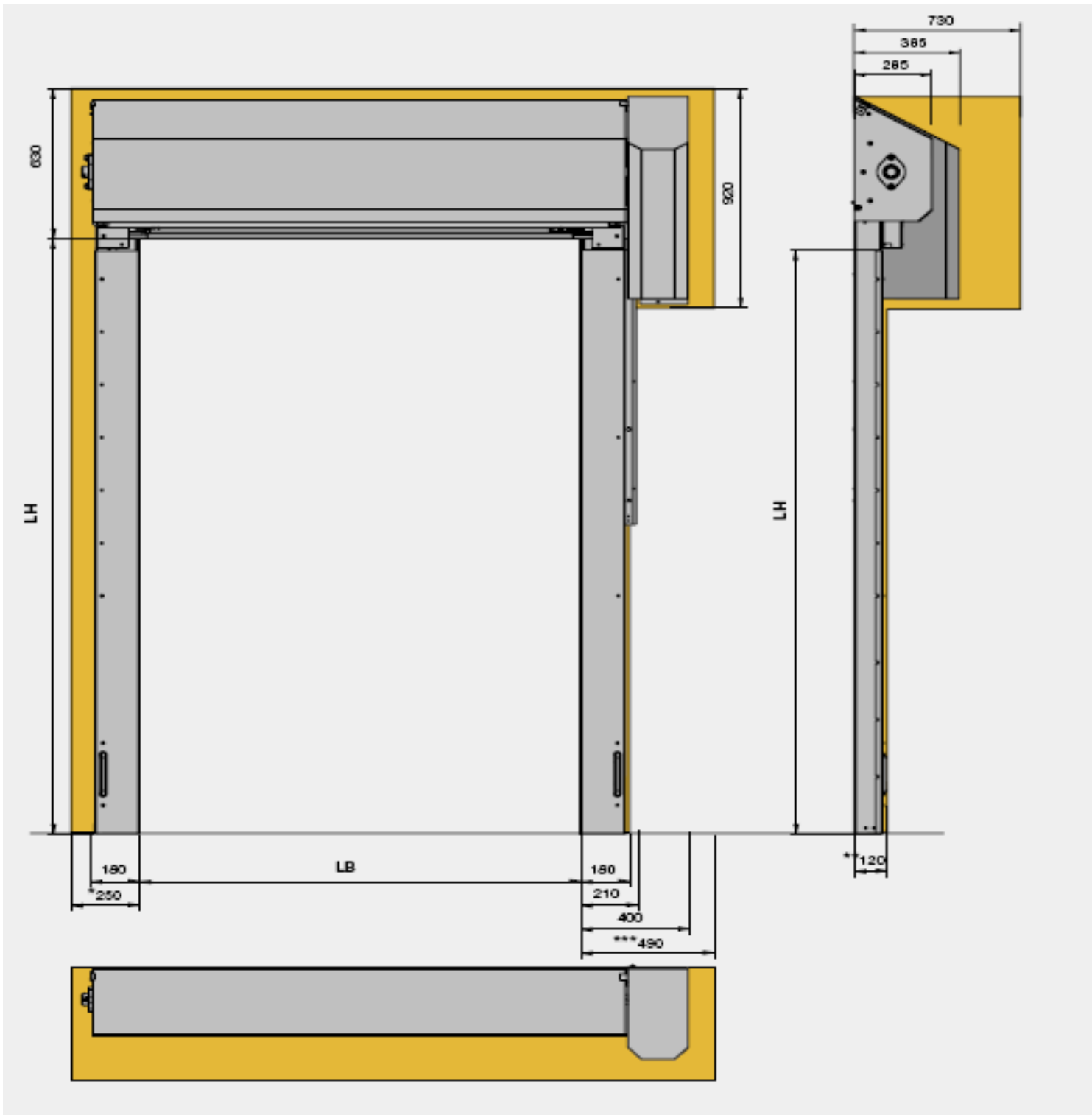

- * For version with emergency opening 320mm
- ** For version with emergency opening 180mm
- *** Space required for dismantling the operator

**General Arrangement of Delta Speed 5030SE
With Full Cladding Angled**

We reserve the right to change specification without prior notification or alteration of this product data sheet.